

# ETAR50L



## PRODUCT SPECIFICATION

ETAR50L

**Materials** Housing-AL, Lens-PC  
**Ambient operating temperature** -25°C to +55°C  
**Volume** Max. 85dB at 1m  
**Protection rating** IP20

- Pole-mounted performance line adopting high-brightness LED as a light source
- A soft and cozy signal light is emitted through the translucent lens
- Excellent durability by using aluminum housing
- Equipped with a foldable bracket to respond to various external environments
- Built-in buzzer type available



ETAR50L

### ETAR50L Industrial LED Beacon

Model number	Layers	Voltage	Current	Certificates	Weight	Color
ETAR50L Steady						
ETAR50L-BZ Steady w/built-in buzzer						
ETAR50LF Flashing	3	DC24V	55mA	CE	0.42kg	<span style="color: red;">●</span> R-Red <span style="color: orange;">●</span> A-Amber <span style="color: green;">●</span> G-Green
ETAR50L F-BZ Flashing w/built-in buzzer						

### Wiring Instructions

- ETAR50L series can be wired by using both external contact and transistor.
- Wiring to transistor, use the PNP transistor. Please wire properly based on wiring instructions.

- ETAR50L / ETAR50L-BZ
- ETAR50LF / ETAR50LF-BZ

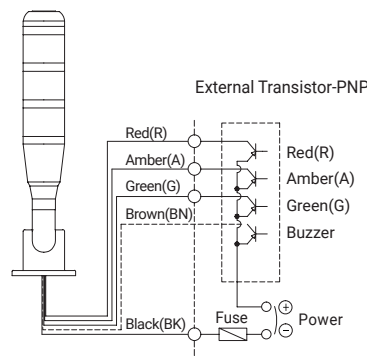
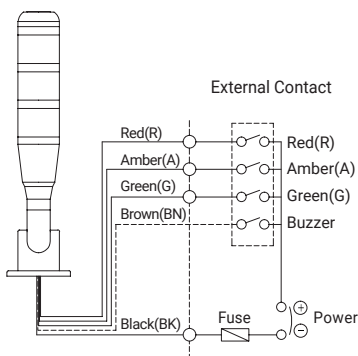

※ ETAR50L / ETAR50L-BZ: Steady, ETAR50LF / ETAR50LF-BZ: Flashing

### Technical Diagram

Units: mm

- ETAR50L / ETAR50L-BZ
- ETAR50LF / ETAR50LF-BZ

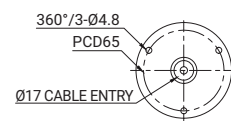
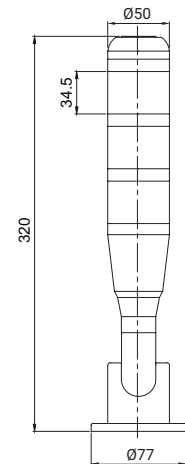

### Ordering Specification

ETAR50L	-	3	-	24	-	RAG
[Model number]		[Layers]		[Voltage]		[Color]
ETAR50L ETAR50L-BZ ETAR50LF ETAR50L F-BZ		3-3 Layers		24-DC24V		<span style="color: red;">●</span> R-Red <span style="color: orange;">●</span> A-Amber <span style="color: green;">●</span> G-Green