

# S80 Series

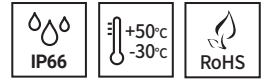

Superior light output similar to xenon lamp through novel diffusion lens



S80NS

## PRODUCT SPECIFICATION

S80NS

**Materials** Lens-PC, Housing-ABS+GF(S80NS), ABS(S80NSE)

**Ambient operating temperature** -30°C to +50°C

**Protection rating** IP66

**Flashing rate** 60-80/min

**Compliant with RoHS directive**

- Ø80mm LED strobe signal lights
- LED lights can be strongly emitted by convex lens
- Adopts excellent light distribution structure
- LED lamp provides high durability in conveyor machines, cars, press machines which have vibration and impact
- Excellent durability and air tightness by sealed PCB
- Adopts strobe type for good visibility



S80NSE

### S80NS LED Strobe Signal Lights

Model number	Voltage	Current	Certificates	Weight	Color
S80NS	DC12V-24V	Max.660mA	CE UL	0.50kg	<ul style="list-style-type: none"> <li>● R-Red</li> <li>● A-Amber</li> <li>● G-Green</li> <li>● B-Blue</li> </ul>

※ DC type model has a free-voltage range of 10V-30V

### S80NSE LED Strobe Signal Lights

Model number	Voltage	Current	Certificates	Weight	Color
S80NSE	DC12V-24V	Max.660mA	CE UL	0.45kg	<ul style="list-style-type: none"> <li>● R-Red</li> <li>● A-Amber</li> <li>● G-Green</li> <li>● B-Blue</li> </ul>

※ DC type model has a free-voltage range of 10V-30V

※ UL compliant: DC24V

### Technical Diagram

Units: mm

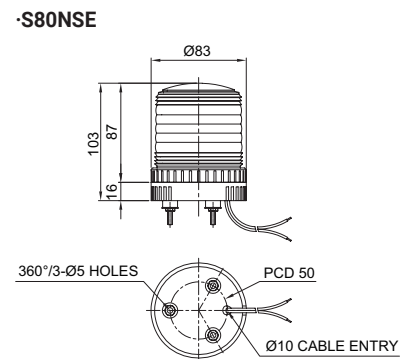
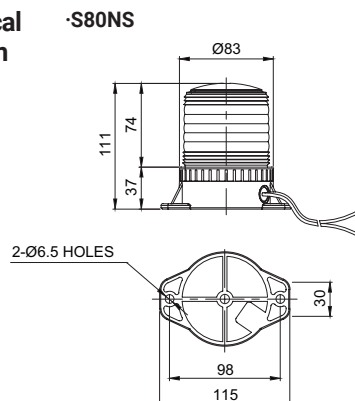

### Wiring Instructions

- External Power line  
UL1015 AWG18(0.75sq) x 2C 400mm
- This product can be wired regardless of polarity.

### Ordering Specification

S80NS	-	12/24	-	A
[Model number]		[Voltage]		[Color]
S80NS S80NSE		12/24-DC12V-24V		<ul style="list-style-type: none"> <li>● R-Red</li> <li>● A-Amber</li> <li>● G-Green</li> <li>● B-Blue</li> </ul>