

INNOVATION in  
ALARM & SIGNAL

# Warning Light Bars

CATALOG 2026



Signal Tower Lights  
Signal Beacons and Sounders  
Heavy-Duty and Explosion Proof Signalings  
**Warning Light Bars**  
Aviation Obstruction Lights  
Smart Factory Products  
Industrial LED Lights  
Performance Line - E Series

**Qlight**

**Qlight**

Gives you a  
Brighter  
Future

---

## Qlight Gives You a Brighter Future!

Qlight has been contributed to an industrial safety and efficiency by producing several audible/ visual signaling devices and industrial LED lights since its establishment in 1986. Our technology and quality are highly reputable among various industries for example semiconductor manufacturing equipment, automobile industry, unmanned automation facility, steel production facility, shipbuilding industry, offshore plant, specialized unit for petrochemical industry based on diverse technology patents and core technologies such as LED light source, heat radiation technology, explosion proof design. Our established local corporations in South Korea and China, sales branches in the United States, Japan, Vietnam, and a global service network provides a distribution and sales system servicing over 80 countries that help Qlight reinforces industrial fields all over the world.



# Qlight is a representative of signaling device in Korea.

Qlight has been striving to accomplish our mission to provide visual and audible status indicating systems and solutions to enhance our customer's work safety and efficiency for the last three decades.

As a market leader, Qlight is going to accomplish our responsibility by introducing state of the art equipment and unmanned facilities.

## 1986 - 1995

### Business foundation and consolidation

- 1986 Established Qlight
- 1993 Nominated for developing domestic explosion proof warning lights by Korean Ministry of Science & Technology

## 1996 - 2005

### Growing as a signal transmission device specialist

- 2001 Established Shanghai Qlight Electronic Co., Ltd. in China



- 2004 ISO 9001:2000 certificates acquired

## 2006 - 2017

### Mission device specialist A great leap forward & business reconstruction

- 2010 Established R&D Center
- 2011 Selected as a venture company
- 2011 Selected as an INNO-BIZ firm which is an innovative tech company
- 2014 Selected as a promising export company by Small and Medium Business Administration(SMBA)
- 2014 Established the Qlight USA, Inc. in San Jose, CA.
- 2016 The second headquarter factory built



# History of Change & Innovation

## 2018 to Present

### New engines for growth

2019 Established Qidong factory



2019 Selected as a family friendly company by Ministry of Gender Equality and Family

2020 Selected as a small giants company by Small and Medium Business Administration(SMBA)

2021 Selected as a youth-friendly small giants company

2023 Selected as the best reading management company by the Ministry of Culture, Sports and Tourism of Korea

## The 2<sup>nd</sup> growth and globalization

# Qlight, the best professional company

Leading the **improvement of industrial efficiency**

## 1 | Aiming for the first-class

Aiming for the first-class specialized company to contribute industrial efficiency and safety of customer based on the core competency of System, Variety, and Hi-quality

## 40 | Continuous growth for about 40 years

Based on a partnership-oriented corporate culture and sharing management, we have grown continuously for 40 years since our founding and are recognized for our quality and technology.

## 80 | Global networks in 80 countries

Exporting to all over the world through global network spanning over 200 distribution channels in 80 countries and brightening industrial sites around the world

## 450 | Multi-variety production

Satisfying various needs of customers through systematic customer-customized production system for over 450 products

### Quick

Prompt customer satisfaction and real time enterprise(RTE)

### Quality

Emphasis on product and service quality, workplace innovation and ethical management

### Question

Problem oriented thinking and creative problem solving are based on achieving strategic task.

### Qualified

The most suitable company that leads the innovation of signaling device technology and industrial efficiency improvement



## Core Competency



### System

Delicate mechanism of the work realizes shorter lead time by effectively managing over-all procedures such as purchasing, production, stock management, and distribution.



### Broad-line

Customers are highly satisfied with Qlight products because we offer over 450 types of wide variety of product family with a systematic customized production system.



### Supreme Quality

Qlight's technological capability and supremacy of quality are being recognized because of our strict technology standard and inspection system. We've obtained over 22 certificates such as IECEx, ATEX, NEPSI, CCS, CE, and UL. We've been expanding it in accordance with industrial demands.

## How Qlight works



# Warning Light/Indicator Light Operating Principle

## SELECTION OF WARNING LIGHT

The selection of signaling devices will depend on the particular situation and environment.

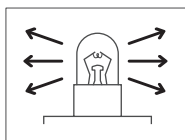

### Bulb Steady/Flashing Type

Highly diffusible light bulb that refracts light through a special lens and can be used in a steady or flashing state

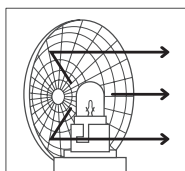

### Bulb Revolving Type

By combining a highly diffusible light bulb and a reflector, light is reflected in a parallel beam with a rotating cycle

Our bulb revolving model has a long lifetime enabled by using a high durability bulb and a power transfer system that minimizes noise and abrasion

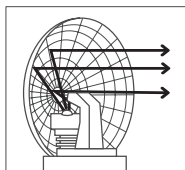

### LED Revolving Type

The combination of an LED and a reflector creates a parallel light beam with a rotating cycle

LED Rotating model with reflector adopts a special light distribution and multiple reflection system that is obtained a patent by Qlight can emit the light intensively and evenly as same as a bulb rotating type with reflector. (Patent No.: 10-0889803, 10-0808669 and 20-2008-0002489)

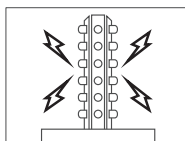

### LED Strobe-Type

By shortening the LED flashing period and supplying the maximum current to the LED, it produces a flash effect just like the xenon lamp



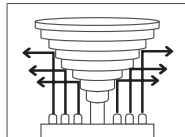

#### LED Steady/Flashing Type

The indirect light distribution system uses a special structure to radiate a uniform light signal throughout the entire body of the lens by using a multi-stage reflector

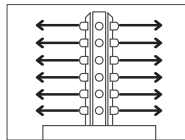

The direct light distribution system uses a high-intensity LED light and diffusion lens to transfer signal over a long distance. Qlight LED lights / flashing lights are equipped with two structures depending on the model type, Steady or Flashing Type

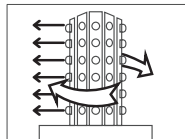

#### LED Simulated Revolving Type

By uniformly arranging the LED lens in a 360 degree circumferential direction, it will produce a flash in a regular rotating sequence. The visual effect looks just the same as the revolving model

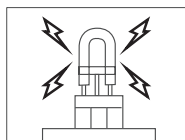

#### Xenon Lamp Strobe-Type

An intensive flashing light emitting model with short term energy consumption that can highly attract worker's attention. Better shock resistance than a conventional bulb and weaker than LED.

Since it adopts intensive xenon lamp light emitting into lens design, it can emit intensive signal light in all directions of the lens.

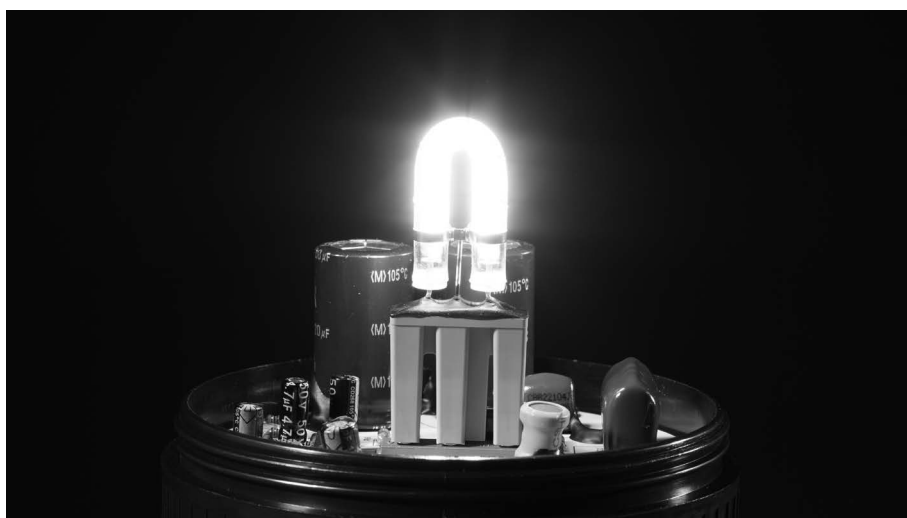















# Waterproof and Dustproof Protection Structure



## Comparing waterproof & dustproof protection structure

IP rating \_ Known as "Ingress Protection rating" indicated in two-digit code showing the amount of protection against solid and the liquid(IEC60529)

# IP 6 7

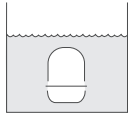
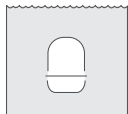
First Number Protection against solid		Second Number Protection against liquid	
0	 No protection	0	 No protection
1	 Protected against solid objects over 50mm, eg accidental touch by persons hands	1	 Protection against vertically falling drops of water eg condensation
2	 Protected against solid objects over 125mm, eg persons fingers	2	 Protection against direct sprays of water up to 15° from the vertical
3	 Protected against solid objects over 25mm (tools and wires)	3	 Protected against direct sprays of water up to 60° from the vertical
4	 Protected against solid objects over 1mm (tools, wires, and small wires)	4	 Protection against water sprayed from all directions - limited ingress permitted
5	 Protected against dust limited ingress (no harmful deposit)	5	 Protected against low pressure jets of water from all directions - limited ingress
6	 Totally protected against dust	6	 Protected against temporary flooding of water, eg for use on ship decks - limited ingress permitted
		7	 Protected against the effect of immersion between 15 cm and 1 m
		8	 Protects against long periods of immersion under pressure

## NEMA SIZE

National Electrical Manufacturers Associations standard for enclosure protection rating, NEMA1-6 and 11-13 type is applicable in Non-Hazardous Locations, NEMA 7-10 is applicable in Hazardous Locations

Type	Usage place	Environment	Protection rating
1	Indoor Use	Non-explosion proof	Intended for indoor use primarily to provide a degree of protection against limited amounts of falling dirt
2	Indoor Use	Non-explosion proof	Intended for indoor use primarily to provide a degree of protection against limited amounts of falling water and dirt
3	Outdoor Use	Non-explosion proof	Intended for outdoor use primarily to provide a degree of protection against rain, sleet, windblown dust; and damage from external ice formation
3R	Outdoor Use	Non-explosion proof	Intended for outdoor use primarily to provide a degree of protection against rain, sleet; and damage from external ice formation, and must have a drain hole
3S	Outdoor Use	Non-explosion proof	Intended for outdoor use primarily to provide a degree of protection against rain, sleet, windblown dust; and to provide for operation of external mechanisms when ice laden
4	Indoor/Outdoor Use	Non-explosion proof	Intended for indoor or outdoor use primarily to provide a degree of protection against windblown dust and rain, splashing water, hose directed water; and damage from external ice formation
4X		Non-explosion proof	Intended for indoor or outdoor use primarily to provide a degree of protection against corrosion, windblown dust and rain, splashing water, hose directed water; and damage from external ice formation
5	Indoor Use	Non-explosion proof	Intended for indoor use primary to provide
6	Indoor/Outdoor Use	Non-explosion proof	Intended for indoor or outdoor use primarily to provide a degree of protection against hose directed water, the entry of water during occasional temporary submersion at a limited depth; and damage from external ice formation
6P		Non-explosion proof	Intended for indoor or outdoor use primarily to provide a degree of protection against hose-directed water, the entry of water during prolonged submersion at a limited depth; and damage from external ice formation
7	Outdoor Use	Explosion proof	Intended for indoor use in locations classified as Class I, Groups A, B, C, or D, as defined in the NEC
8	Indoor/Outdoor Use	Explosion proof	Intended indoor or outdoor use in locations classified as Class I, Groups A, B, C, or D, as defined in the NEC
9	Indoor Use	Explosion proof	Intended for indoor use in locations classified as Class II, Groups E, F, and G, as defined in the NEC
10	Indoor/Outdoor Use	Explosion proof	Are constructed to meet the applicable requirements of the Mine Safety and Health Administration (MSHA)
11	Indoor Use	Non-explosion proof	Protection from the corrosive effects of liquids and gases by oil immersion
12	Indoor Use	Non-explosion proof	Intended for indoor use primarily to provide a degree of protection against circulating dust, falling dirt, and dripping non-corrosive liquids
12K	Indoor Use	Non-explosion proof	Intended knockouts are intended for indoor use primarily to provide a degree of protection against circulating dust, falling dirt, and dripping non corrosive liquids
13	Indoor Use	Non-explosion proof	Intended for indoor use primarily to provide a degree of protection against dust, spraying of water, oil, and non-corrosive coolant

## NEMA Ratings and IP Ratings Equivalency Chart









The chart below is for comparison between two enclosure ratings It is only for reference and these two rating standards are not exactly converted

NEMA ENCLOSURE TYPE	IP ENCLOSURE TYPE
1	IP20
2	IP22
3	IP55
4	IP66
4X	IP66
6	IP67
12	IP54
13	IP54







# Icon Description

This catalogue helps users quickly identify the product's specifications and features by using several types of icons. If you understand the concept for each icon, you will find it easy to understand the catalogue information.







## Light Source and Operating Mode Icons

Icon	Operating Mode	Icon	Operating Mode
	Bulb steady type		Bulb steady/flashing type
	Bulb revolving type		LED revolving type
	LED steady type		LED steady/flashing type
	LED simulated revolving type		LED strobe type
	Xenon lamp strobe type		

## Acoustic Signal Icons

Icon	Siren	Icon	Siren
	Buzzer		Speaker
	Horn		Bell
	Motor siren		MP3
	Volume(dB)		

## Specifications Icons

Icon	Specification	Icon	Specification
	Magnet type		Ambient operating temperature
	NPN type transistor		PNP type transistor
	IP rating		Wireless Network
	RoHS		

# Warning Light Bars



References

P. 12

Product specifications

P. 13

# Specification List for Warning Light Bars



Model number	QLV	QLV-SET	ELML	ELM-SOL	SAMP
<b>Voltage</b>	DC12V	DC12V	DC12V, DC24V	12V(Battery voltage)	DC12V, DC24V
<b>Dimension (mm)</b>	<b>Outdia</b>	300 x 64	300 x 64	506 x 497(Total)	175(Width)
	<b>Height</b>	129	129	497	73
	<b>Depth</b>	885-1250(Length)	885-1250(Length)	588-1708(Length)	1148
<b>Materials</b>	Lens-PC, Cover-Al, Board-Al, Bracket-STS	QLV-PC Other SAMP-100-Steel SM-100ND-Steel	Lens-PC, Speaker Cover-STS, Reflector-Heat resistant ABS, Board-Al	Lens/Housing-PC, Speaker Cover-STS, Reflector-Heat resistant ABS, Board-Al	Housing-SUS
<b>Light source &amp; Operation</b>	<b>LED Strobe</b>	●	●	●	●
<b>Sound &amp; Volume</b>	-	Max.135dB at 1m	Max.126dB at 1m	-	-
<b>Mounting structure</b>	Direct mount	Direct mount	Direct mount	Direct mount	Bracket mounting type
<b>Cable entry</b>	BCG-M20-14	BCG-M20-14			
<b>Protection rating</b>	IP56	IP56	IP56	IP56	-
<b>Mounting location</b>	Indoor Use	Indoor Use	Indoor Use	Indoor Use	Indoor Use
<b>Mounting direction</b>	Vertical	Vertical	Vertical	Vertical	Vertical, Horizontal, Reverse vertical
<b>Certificates</b>	CE	CE			
<b>Customization</b>					
<b>Page</b>	P13-14	P15	P18-19	P20	P21



Model number	SAMP-100	SM-100ND	
<b>Voltage</b>	DC12V	DC12V	
<b>Dimension (mm)</b>	<b>Outdia</b>	175(Width)	Ø122
	<b>Height</b>	50	-
	<b>Depth</b>	185	118(Length)
<b>Materials</b>	Housing-Steel	Housing-Steel	
<b>Sound &amp; Volume</b>	-	Max.135dB at 1m	
<b>Mounting structure</b>	Bracket mounting type		
<b>Cable entry</b>			
<b>Protection rating</b>			
<b>Mounting location</b>	Indoor Use	Indoor Use	
<b>Mounting direction</b>	Vertical, Horizontal, Reverse vertical	Vertical, Horizontal, Reverse vertical	
<b>Certificates</b>	CE	CE	
<b>Customization</b>			
<b>Page</b>	P16-17	P16-17	

# Warning Light Bars for Emergency Vehicles

## QLV Series



Aerodynamic LED Light Bar Suitable for High Speed Emergency Vehicles



### PRODUCT SPECIFICATION

QLV Series

- Materials** QLV Light Bar Model: Lens-PC, Cover-AL, Board-AL, Mount bracket-STS  
QLV-SET: QLV Light Bar Model-PC other/ SAMP-100-Steel, AL/ SM-100ND-Steel
- Ambient operating temperature** -30°C to +50°C
- Protection rating** IP56
- Lens color** ●● Blue-Red ●● Red-Red ●● Amber-Amber ●● Green-Green
- Flashing rate** 60-80/min(QLV, QLV-SET)

- Compact and aerodynamic design minimizes air resistance in high speed vehicles
- Transparent polycarbonate outer and inner lens provides clear signal light transmission
- Strong mechanical strength, heat, and UV light resistance
- Excellent protection from vibration and impact with use of aluminum boards for both the top and bottom plates
- Internal heat discharges naturally because each LED module adopts an excellent heat dissipative structure
- QLV-SET includes amplifier that has a built-in one-touch switch for selection between signal sound and warning light
- QLV-SET includes a 100W high volume horn with clear warning sounds
- 1,250mm, 1,150mm and 885mm length models are also available
- Available in customized color arrangements

### Product Features

- 1** High volume, high quality horn system  
· 100W high power volume horn

- 2** AMP  
· Choose Lightbar function & alarm tone

- 4** Module  
· Take Down Module: Intense white Light  
· LED Module: Clear color signal light



# Warning Light Bars for Emergency Vehicle

## QLV Series



QLV-1250



QLV-1150



QLV-885

### QLV LED Strobe Warning Light Bar

Model number	LED module number	Voltage	Current	Certificate	Weight	Color
QLV-1250	24EA		11A	CE	16.51kg	●● B-R ●● R-R ●● A-A ●● G-G
QLV-1150	22EA	DC12V	10.5A	-	15.62kg	
QLV-885	18EA		9.5A	-	12.97kg	

- Excellent light transmission with use of 24 High brightness LED Strobe modules
- Replaceable LED module design

### QLV Signal Light Functions

No.	Function
1	Full LED Strobe
2	LED Simulated revolving
3	Front & rear simulated revolving
4	TAKE DOWN LED Steady
5	NIGHT LED Steady(NIGHT MODE)

### Wiring Instructions

#### ·QLV-DC

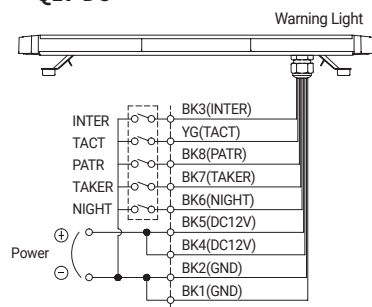

### Technical Diagram

Units: mm

#### ·QLV-1250

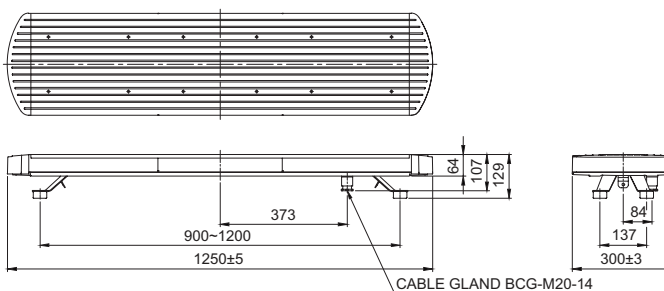

#### ·QLV-1150

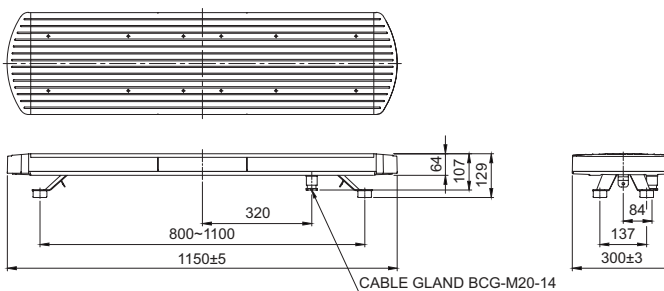

#### ·QLV-885

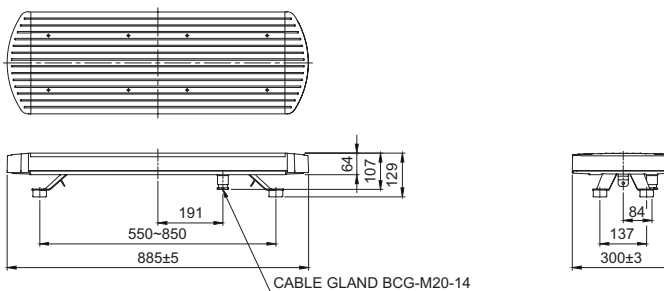

### Ordering Specification

QLV-1150	-	12	-	B/R
[Model number]		[Voltage]		[Color]
QLV-1250 QLV-1150 QLV-885		12-DC12V		B/R ●● Blue-Red R/R ●● Red-Red A/A ●● Amber-Amber G/G ●● Green-Green

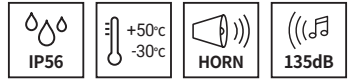

## QLV-SET LED Strobe Light Bar SET

Model number	LED module number	Voltage	Current	Volume	Certificate	Weight	Color
QLV-1250-SET	24EA		26.5A			20.31kg	●● B-R
QLV-1150-SET	22EA	DC12V	26A	Max. 135dB	CE	19.42kg	●● R-R ●● A-A
QLV-885-SET	18EA		25A			16.77kg	●● G-G

- Features high intensity LED strobe modules
- Amplifier includes built-in one-touch switch for selection between signal sound and warning light
- 100W high volume speaker with clear warning sounds



QLV-SET

### Technical Diagram

Units: mm

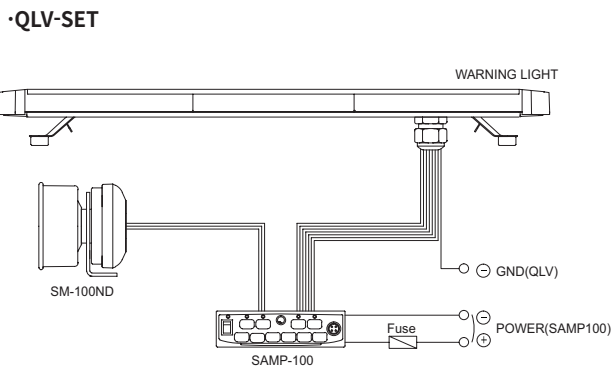

### Wiring Instructions

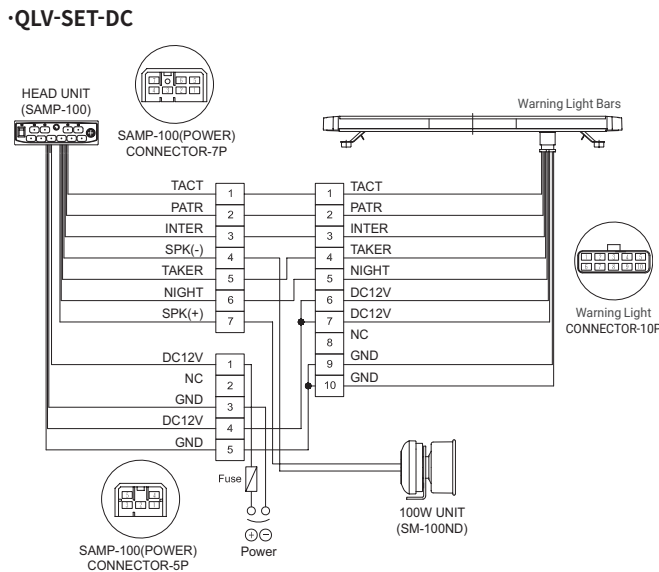

### QLV-SET Signal Light and Sound Functions

No.	Mode	Function
	TACT(LED Strobe)	Full LED strobe
	PATR (Repeated sequential flashing)	Sequential flashing - from middle to outside direction
Light Modes	INTE(Sequential flashing)	Sequential flashing(Front/Rear modules only) - from left to right direction
	TAKE(LED steady)	Take down LED steady
	NIGH(Night steady)	Night LED steady (Night mode)
	WAIL(Fire Alarm)	Fire Alarm sound
	YELP(Emergency)	Emergency sound
Sound Modes	HORN	Horn sound
	MIC	Microphone output mode
	TOOL(Special tone)	Special tone (DI-DI-DI-DI)
	H/L(Ambulance tone)	Ambulance (PI-PO)

### Ordering Specification

QLV-1150	-	12	-	B/R	-	SAMP	-	HORN
[Model number]		[Voltage]		[Color]		[AMP]		[HORN]
QLV-1250		12-DC12V		B/R ●● Blue-Red		SAMP		HORN
QLV-1150				R/R ●● Red-Red		- SAMP-100		- SM-100ND included
QLV-885				A/A ●● Amber-Amber		included		
				G/G ●● Green-Green				

# Controllable AMP for QLV Warning Light Bar

## SAMP-100 / SM-100ND



Recommended Amplifier Designed for QLV Warning Light Bar



SAMP-100

### SAMP-100 controllable AMP for QLV Warning Light Bar

Model number	Voltage	Current	Sound pattern	Frequency/ Repeat time	Certificate	Weight
SAMP-100	DC12V	15.5A	Fire Alarm	300-700Hz/140cycle	CE	1.15kg
			Emergency	350-750Hz/14cycle		
			Horn	600Hz-91KHz		
			Buzzer	2.25Hz/90cycle		

- Simple linkage between sound signal and warning lights
- Clear and stable sound signal
- Built-in switch for emergency voice on the microphone
- Amplifier is already part of QLV-SET model



SM-100ND

### SM-100ND Horn for Warning Light Bars

Model number	Voltage	Volume	Certificate	Weight
SM-100ND	DC12V	Max.135dB	CE	1.15kg

- 100W high volume horn with clear warning sounds
- Mounting bracket for applications in various environments

### Wiring Instructions

#### ·SAMP-100 / SM-100D

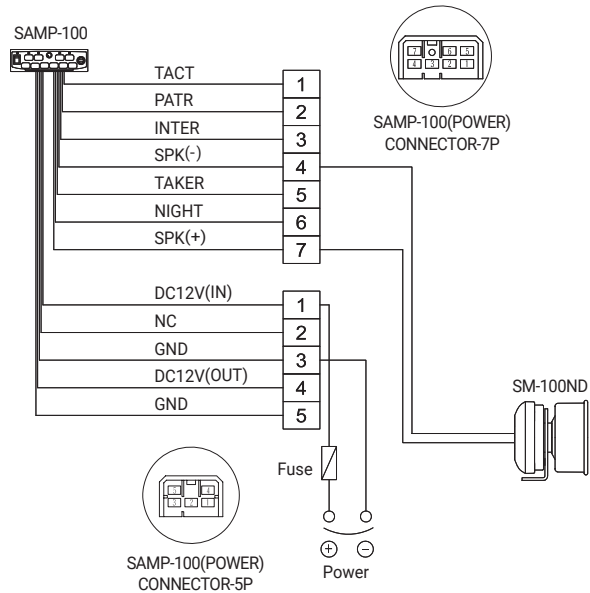

### Ordering Specification

SAMP-100	-	12
[Model number]		[Voltage]
SAMP-100		12-DC12V
SM-100ND		

# Technical Diagram

Units: mm

## ·SAMP-100

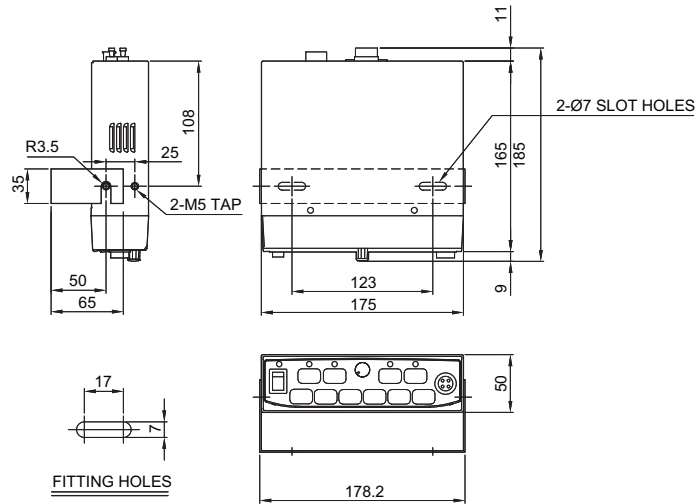

## ·SM-100ND

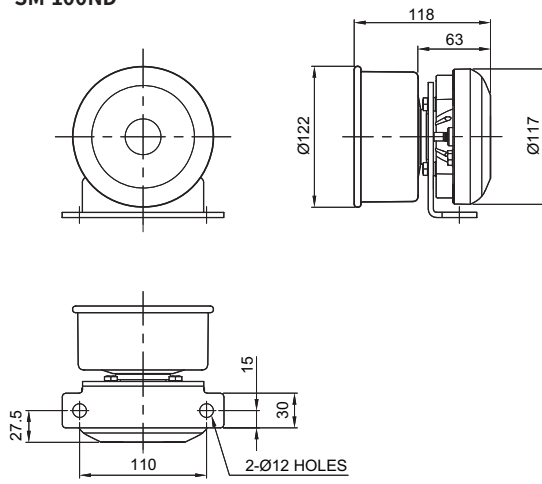

# Warning Lights for Road Safety (Max.126dB)

## ELML

Various combinations of sizes, color, and light source depending on the application needs

### PRODUCT SPECIFICATION

ELML



ELML

**Materials** Lens-PC, Speaker Cover-STS, Reflector-Heat resistant ABS, Board-Al  
**Ambient operating temperature** -25°C to +50°C  
**Built-in speaker, volume** Max.126dB at 1m  
**Protection rating** IP56  
**Flashing rate** 60-80/min

- Adjustable size depending on the type of vehicle and application needs
- Suitable for tow trucks, patrol cars and parking lots
- Adjustable size depending on the type of vehicle and application needs
- Suitable for tow trucks, patrol cars and parking lots
- Designed in a structure which allows for quick assembly and disassembly for convenient light source replacement
- Customized color arrangements available
- Modular design allows user defined color arrangement if necessary

### ELML LED Strobe Warning Light Bar

Model number	LED module number	Voltage	Current	Certificate	Weight (Based on 3 layers)	Color
ELML-1	4EA	DC12V	1.6A			
		DC24V	1.2A			
ELML-2	8EA	DC12V	2.4A			
		DC24V	1.65A			
ELML-3	12EA	DC12V	3.5A		11.02kg	
		DC24V	3A			
ELML-4	16EA	DC12V	5.1A			
		DC24V	4.2A			
ELML-5	20EA	DC12V	5.8A			
		DC24V	4.7A			

### Technical Diagram

Units: mm

·ELML

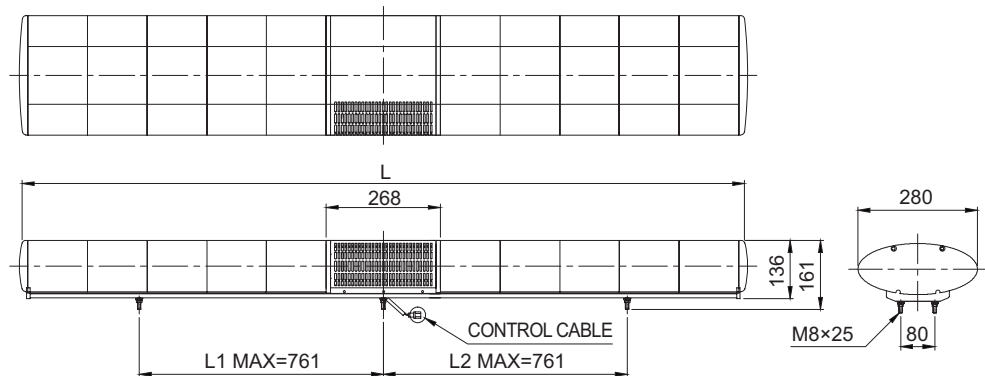

L(LENGTH)	
ELML-1(BLOCKS 2)	588mm
ELML-2(BLOCKS 4)	868mm
ELML-3(BLOCKS 6)	1148mm
ELML-4(BLOCKS 8)	1428mm
ELML-5(BLOCKS 10)	1708mm

· Power line specification ICE57(0.75sq) x 4C 3m

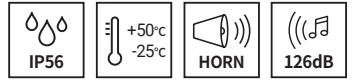

## Wiring Instructions

·ELML-DC

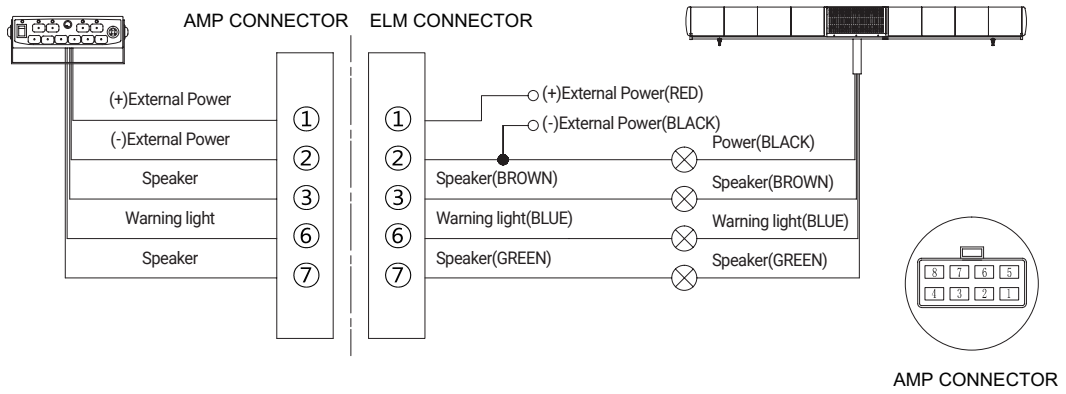

## Ordering Specification

<b>ELML</b>	-	<b>4</b>	-	<b>12</b>	-	<b>B/R</b>	-	<b>SAMP</b>
[Model number]		[Layer]		[Voltage]		[Color]		[AMP]
ELML		1-1layer 2-2layers 3-3layers 4-4layers 5-5layers		12-DC12V 24-DC24V		B/R ●● Blue-Red R/R ●● Red-Red A/A ●● Amber-Amber		None - No AMP SAMP - AMP included

# Solar Powered Warning Light Bar

## ELM-SOL



Solar powered warning light bar for road safety(road safety)



ELM-SOL

### PRODUCT SPECIFICATION

ELM-SOL

**Materials** Lens/Housing-PC, Speaker Cover-STS, Reflector-Heat resistant ABS, Board-Al

**Ambient operating temperature** -25°C to +50°C

**Protection rating** IP56

**Flashing rate** 60-80/min

- Semi-permanent lifetime by adopting high brightness LED
- Solar powered design does not require a power system(Built-in rechargeable battery)
- Built-in SUN switch activates a system that automatically operates the product when darkness is detected
- Operates for 96 hours upon full charge

### ELM-SOL Solar Powered Warning Light Bar

Model number	Battery voltage	Battery capacity	Running time	Certificate	Weight
ELM-SOL	12V	12Ah	96 hour	-	12.80kg

### Technical Diagram

Units: mm

·ELM-SOL

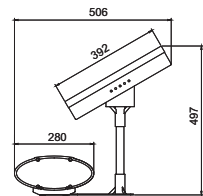
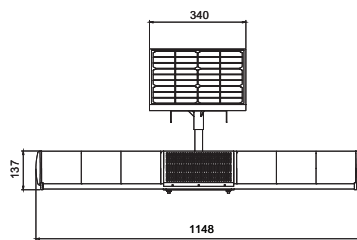

# Controllable AMP for Warning Light Bar

## SAMP

Signal sound AMP for ELML

### SAMP Controllable AMP for Warning Light Bar

Model number	Voltage	Current	Sound pattern	Frequency/Repeat time	Certificate	Weight
SAMP	DC12V DC24V	5.2A 2.5A	Fire	300-700Hz /140cycle	-	1.09kg
			Emergency	350-750Hz /14cycle		
			Ambulance	610-690Hz /50cycle		
			Buzzer	2,200Hz		
			Horn sound	595Hz-1,040Hz		



SAMP

- Simple linkage between sound signal and warning lights
- Clear and stable sound signal
- Built-in switch for emergency voice on the microphone

### Technical Diagram

Units: mm

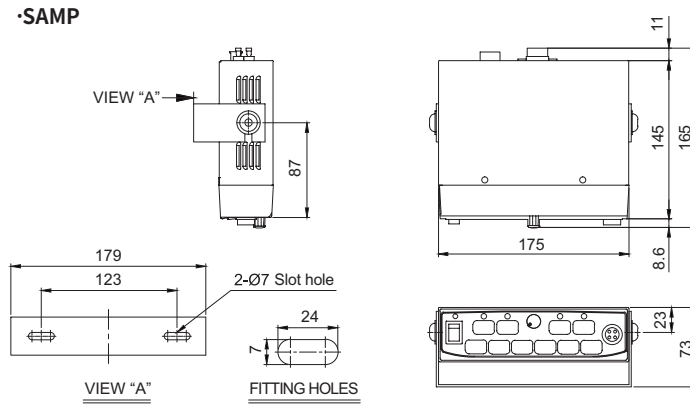

### Wiring Instructions

·SAMP-DC

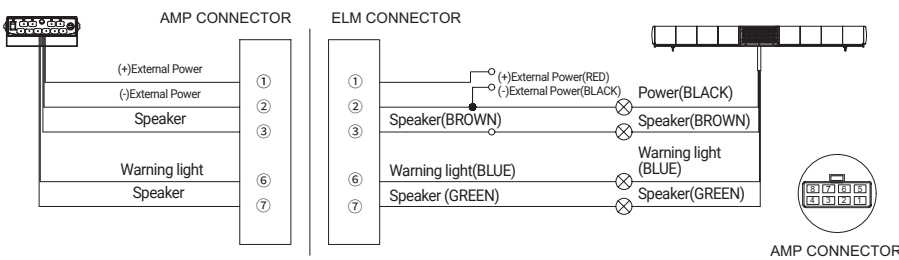

### Ordering Specification

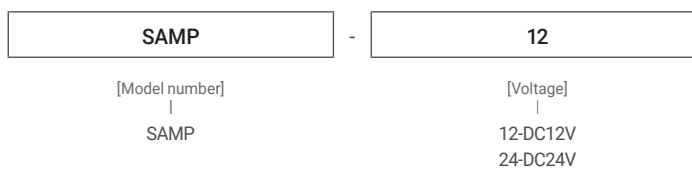

# Global Networks



## Qlight Korea

Head Office  
 Suite #1510, STX-V Tower, 128 Gasan digital 1-ro, Geumcheon-gu, Seoul, Korea  
 Gimhae Production Headquarters  
 185-25, Mukbang-ro, Sangdong-myeon, Gimhae-si, Gyeongsangnam-do, Korea  
 Busan Business Center  
 704, Nakdong-daero, Sasang-gu, Busan, Korea(Eomgung-Dong)



## Qlight China Corporation

Sales Office (Shanghai)  
 Room 333 Building B, #11, Lane 450, Zhenda Road, Baoshan District, Shanghai, China  
 Qlight China Factory (Qidong)  
 #33, Haiyan Road, Qidong High-tech Industrial Development Zone,  
 Qidong, Jiangsu Province, China

### Qlight Clients

Heavy industry/Ship building/Automotive/Steel/Machinery/Petrochemical/Power plants/Electronics/Semiconductor/Emergency Vehicles



Qlight products have been exported all over the world in recognition of excellent technical capabilities and exceptional quality. Qlight products are going to be distributed a lot more countries in the future.

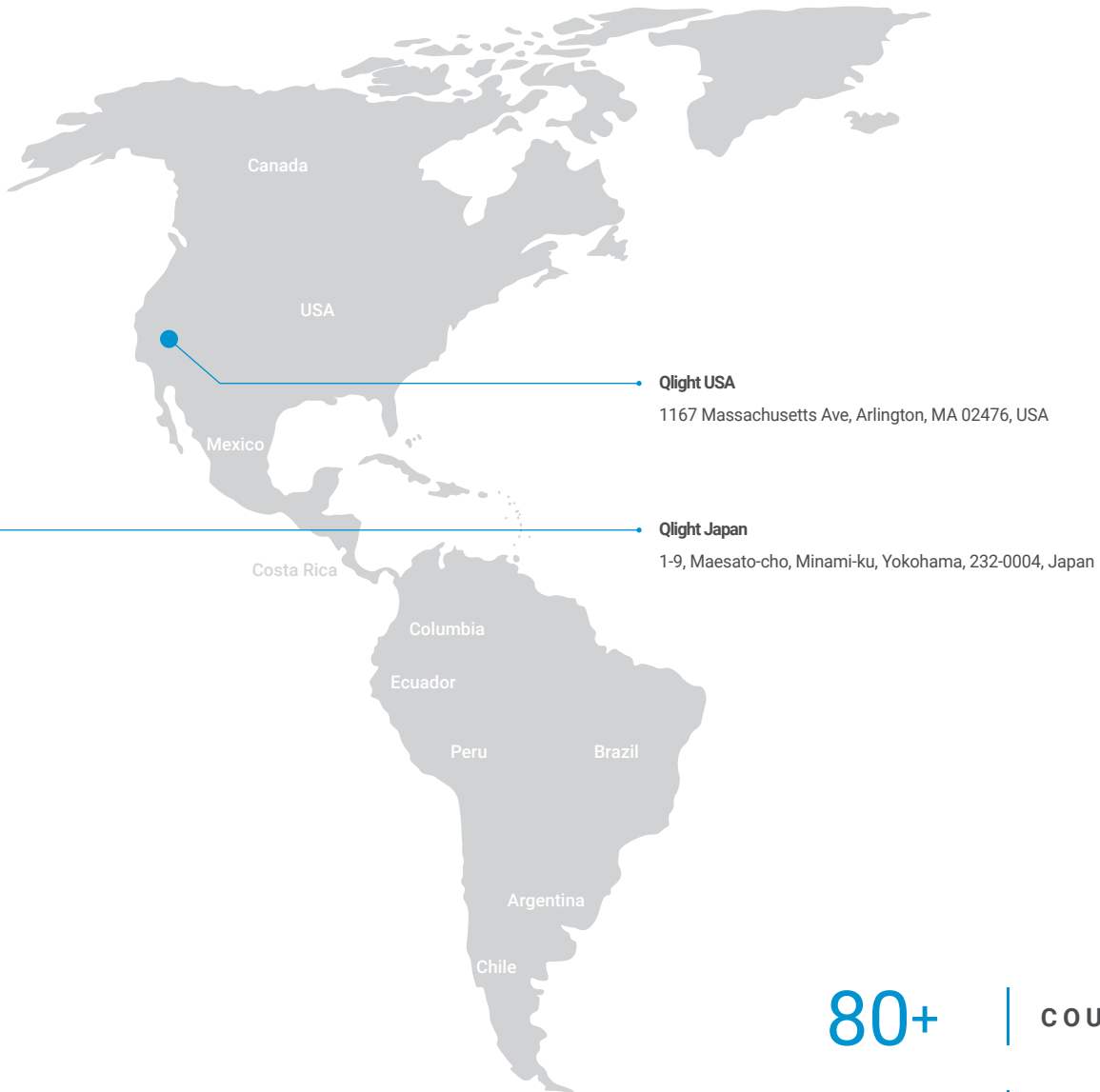

**80+** | COUNTRIES  
**250+** | DISTRIBUTORS



# Technical Certification

Qlight products are designed to meet strict quality and technical standards. Thus, the Qlight brand is widely recognized for its high quality and technical innovations from leading institutions around the world.



**ISO**  
International Organization for Standardization



**IECEX**  
International Explosion Proof Certification (IECEX)



**ATEX**  
The European Regulatory Framework of Manufacture, Installation and Use of Equipment in Explosive Atmospheres



**NEPSI**  
National Center for Explosion Protection and Safety of Instrumentation



**NRTL**  
Certified by designated U.S. laboratory  
Intertek



**KCs**  
Korea safety Certification



**TIIS**  
Technology Institution of Industrial Safety



**CCS**  
China Classification Society



**TS**  
Industrial Safety Technology Institute of Taiwan



**FCC**  
Federal Communications Commission



**S-mark**  
Safety Certification



**KC**  
Korea Certification Mark



**CCC**  
China Compulsory Certificate



**CCCF**  
China Certification Center for Security & Protection



**UL**  
Underwriters Laboratories



**CE**  
European Commission



**ICAO**  
International Civil Aviation Organization



**RoHS2**  
Restriction of Hazardous Substances Directive

# Qlight Catalog Introduction

Qlight produces a wide variety of product categories which offers the customer the ability to select the suitable device for their application needs and environments. There are signal tower lights, Signal Beacons and Sounders, Heavy-Duty and Explosion Proof Signalings, Warning light bars, Aviation Obstruction Lights, Smart Factory Products, Industrial LED lights, and Performance Line - E Series



Signal Tower Lights



Signal Beacons and Sounders

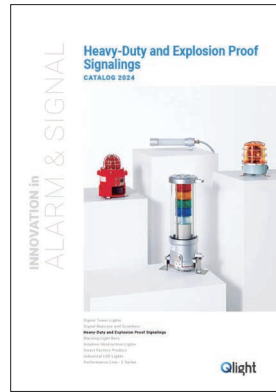

Heavy-Duty and Explosion Proof Signalings

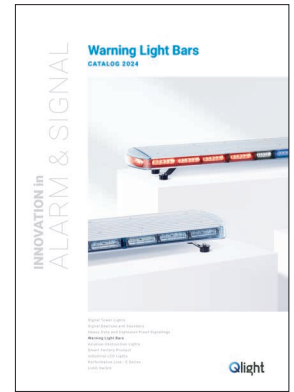

Warning Light Bars



Aviation Obstruction Lights

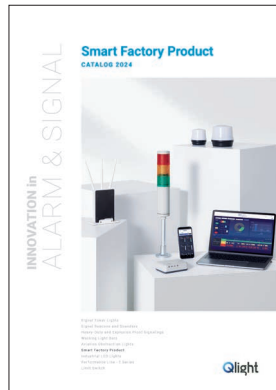

Smart Factory Products



Industrial LED Lights

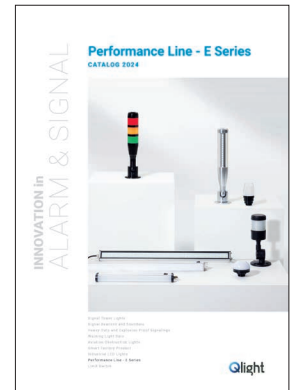

Performance Line - E Series

**You could download and find the latest Catalog on the Qlight website.**

\* The latest product information could be accurately checked on the Qlight website ([www.qlight.com](http://www.qlight.com)). Please refer to the user manual attached with the product before installation and use.



**Korea Corporation Qlight Co., Ltd. www.qlight.com trade@qlight.com**

**Headquarters** Suite #1510, STX-V Tower, 128 Gasan Digital 1-ro, Geumcheon-gu, Seoul, 08507, South Korea **Tel:** +82-2-2679-6152 **Fax:** +82-2-2679-6154

**Gimhae Production Headquarters** 185-25, Mukbang-ro, Sangdong-myeon, Gimhae-si, Gyeongsangnam-do, 50805, South Korea **Tel:** +82-55-328-1111

**Overseas Sales Department** Qlight Building, 704 Nakdong-daero, Sasang-gu, Busan 47044, South Korea **Tel:** +82-51-620-4100

**Busan Business Center** Qlight Building, 704 Nakdong-daero, Sasang-gu, Busan 47044, South Korea **Tel:** +82-51-245-0017

-

**China Corporation SHANGHAI Qlight Electronic Co., Ltd. www.qlight.com www.qlightcn.com qlightcn@qlight.com**

**Sales Corporation (Shanghai)** Room 333 Building B, No.11, Lane 450, Zhenda Road, Baoshan District, Shanghai, China **Tel:** +86-21-6651-7100 **Fax:** +86-21-6315-3929

**Manufacturing Corporation (Qidong)** No.33, Haiyan Road, Qidong High-tech Industrial Development Zone, Qidong, Jiangsu Province, China

**Tel:** +86-513-8384-9999 **Fax:** +86-513-8384-9910