

# QTEX Series

Explosion proof LED tower lights with flame proof housing



QTEX Self mount



QTEX Wall mount

## PRODUCT SPECIFICATION

QTEX | QTEXB

### Materials

Lens-Tempered glass, Filter Lens-AS, Housing-Al, Reflector-Heat resistant ABS

**Ambient operating temperature**  $-40^{\circ}\text{C} \leq T_{\text{amb}} \leq +60^{\circ}\text{C}$

**Sound volume** Max.90dB at 1m(QTEXB)

### Explosion protection rating

IECEX - Ex db II C T6 Gb, IP66

Ex tb IIIC T85°C Db, IP66

ATEX - EX II 2G Ex db II C T6 Gb, IP66

EX II 2D Ex tb IIIC T85°C Db, IP66

KCs - Ex d II C T6, IP66

**Certificates** IECEX, ATEX, KCs, TS, TIIS(QTEXB only)

**Cable entry** 3/4" NPT 2WAY

- Explosion proof LED tower lights with Ex d IIC rating can be used in explosive gas environments
- Excellent distance visibility by using a special reflector to aggregate the light from the LED filament
- Ø80 LED tower light mounted inside the flame proof housing
- Aluminum housing provides excellent durability
- Long-lasting high intensity LED light source
- Terminal box located inside the housing for easy power wiring
- Direct mount type and wall mount type available depending on application needs.

## QTEX Explosion Proof LED Tower Lights with Flame Proof Housing

Model number	Layer	Voltage	Certificates	Weight	Color
QTEX (Steady/Flashing)	1	DC12V		4.01kg	● R-Red
		DC24V		4.01kg	
		AC95V-230V		4.02kg	
	2	DC12V		4.15kg	● R-Red ● A-Amber ● G-Green
		DC24V		4.15kg	
		AC95V-230V		4.16kg	
	3	DC12V	IECEX ATEX	4.31kg	● R-Red ● A-Amber ● G-Green
		DC24V		4.31kg	
		AC95V-230V		4.32kg	
	4	DC12V	KCs TS	4.46kg	● R-Red ● A-Amber ● G-Green ● B-Blue
		DC24V		4.46kg	
		AC95V-230V		4.47kg	
	5	DC12V		4.61kg	● R-Red ● A-Amber ● G-Green ● B-Blue ○ W-White
		DC24V		4.61kg	
		AC95V-230V		4.62kg	

### Light source current(based on 1 layer)

Voltage	DC12V	DC24V	AC95V-230V
Light source current(1 layer)	80mA	60mA	Max.55mA



## QTEXB Built-in Siren Buzzer Type Explosion Proof LED Tower Lights with Flame Proof Housing

Model number	Layer	Voltage	Certificates	Weight	Color
QTEXB (Steady/Flashing)	1	DC12V		4.11kg	● R-Red
		DC24V		4.11kg	
		AC95V-230V		4.12kg	
	2	DC12V	   	4.25kg	● R-Red
		DC24V		4.25kg	● A-Amber
		AC95V-230V		4.26kg	● G-Green
	3	DC12V		4.41kg	● R-Red
		DC24V		4.41kg	● A-Amber
		AC95V-230V		4.42kg	● G-Green
	4	DC12V		4.56kg	● R-Red
		DC24V		4.56kg	● A-Amber
		AC95V-230V		4.57kg	● B-Blue
	5	DC12V		4.71kg	● R-Red
		DC24V		4.71kg	● G-Green
		AC95V-230V		4.72kg	● B-Blue ○ W-White



QTEXB Self mount



QTEXB Wall mount

- Explosion proof LED tower lights with visual & audible signal that can be used in hazardous environments
- Sound tone & volume: Siren buzzer, Max.90dB at 1m

### Light source/buzzer current(based on 1 layer)

Voltage	DC12V	DC24V	AC95V-230V
Light source current(1 layer)	80mA	60mA	Max.55mA
Buzzer current	60mA	120mA	Max.80mA

### Explosion proof structure for buzzer model

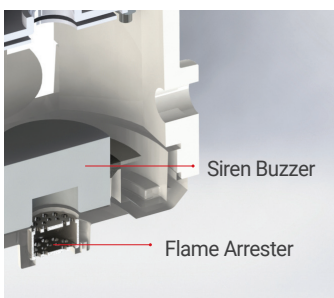

#### · FLAME ARRESTER

A flame arrester(also called a deflagration arrester) functions by absorbing the heat from a flame front traveling at sub-sonic velocities, thus dropping the burning gas/air mixture below its auto-ignition temperature: consequently, the flame cannot survive. The heat is absorbed through channels (passages) designed into an element.

### Ordering Specification

QTEX	-	3	-	12	-	RAG	-	IECEx
[Model number]		[Layer]		[Voltage]		[Color]		[Certificates]
QTEX		1-1Layer		12-DC12V		● R-Red		IECEx
QTEXB		2-2Layers		24-DC24V		● A-Amber		ATEX
		3-3Layers		95/230-AC95V-230V		● G-Green		KCs
		4-4Layers				● B-Blue		TIIS(QTEXB only)
		5-5Layers				○ W-White		

### Customization

- Explosion proof cable gland attached type available (Standard type does not come with explosion proof cable gland)
- Cable entry  
1/2"NPT, M20X1.5, M25X1.5,  
1/2"PF(KCs only),  
3/4"PF(KCs only)

# Explosion Proof LED Tower Lights Flame Proof Housing

## QTEX Series

### Technical Diagram

Units: mm

#### · QTEX / QTEXB-Self mount

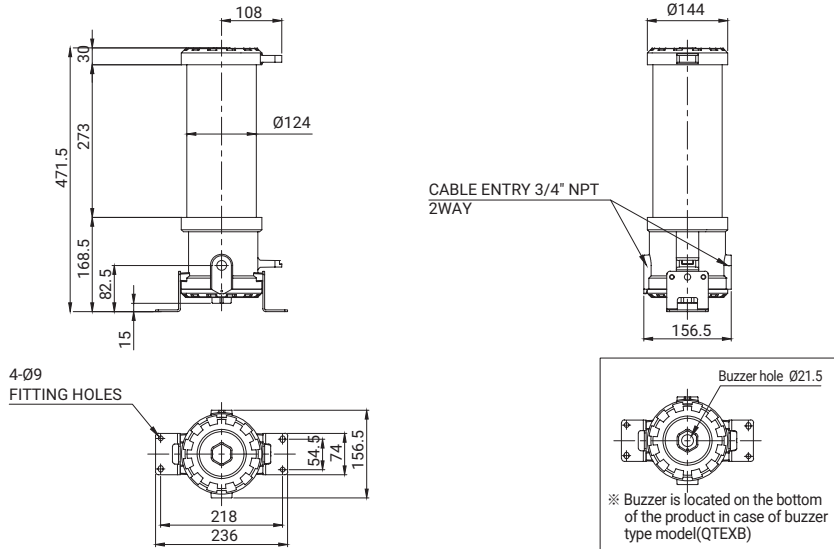

#### · QTEX / QTEXB-Wall mount

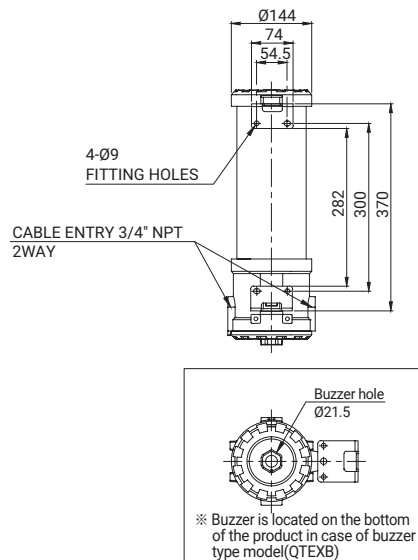

### Cautions in using explosion proof tower lights

- Explosion proof products should be maintained by explosion proof regulation, please do not disassemble, assemble, modify or repair arbitrarily. In case disassembly is required for wiring or repair, structures such as the contact parts should maintain the same initial condition that we provided.
- Cable gland must be used in explosion proof certified products which satisfy the T6 temperature rating and IP66 protection rating.

## Wiring Instructions

- QTEX / QTEXB wiring with transistors and External Contacts.
- In case of wiring with transistors, please use PNP transistors and wiring exactly following below technical diagram.

### External Contacts type

QTEX-DC/AC  
QTEXB-DC/AC

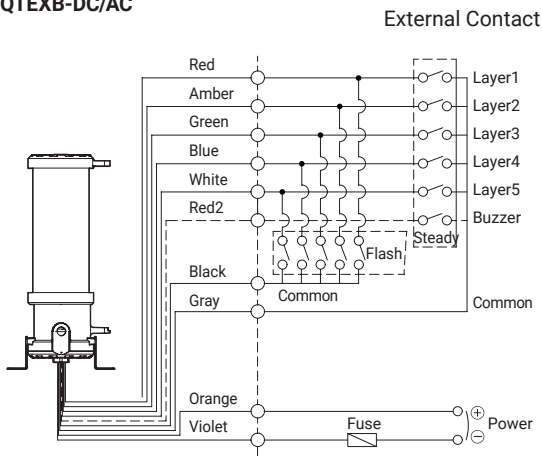

### Transistor type

QTEX-DC/AC  
QTEXB-DC/AC

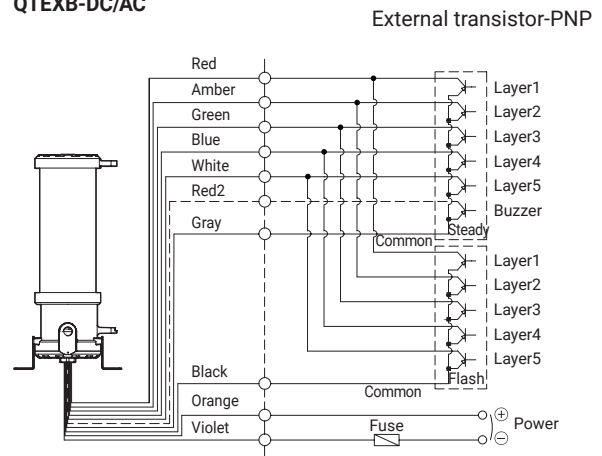

## Terminal Wiring Information

