

# SEA Series



SEALR



SEAL

## PRODUCT SPECIFICATION

SEALR | SEAL | SEAS | SEA

**Materials** Lens-Tempered glass, Filter-PC, Housing-Al, Protection cage-ST316L, Reflector-PC, Reflector-Heat resistant ABS

**Ambient operating temperature**

-20°C ≤ Tamb ≤ +60°C(TS)

-40°C ≤ Tamb ≤ +60°C

**Explosion protection rating**

IECEX - Ex db IIC T6 Gb, IP66

ATEX - Ⓢ II2G Ex db IIC T6 Gb, IP66

KCs - Ex d IIC T6 IP66

NEPSI, CCC, CCS - Ex db IIC T6 Gb

TS - Ex db IIC T6 IP66 Gb(SEAL)

**Certificates** IECEX, ATEX, NEPSI, CCC, KCs, CCS, TS

**Housing standard color** MUNSELL No. 7.5BG 7/2

**Cable entry** 1/2" NPT

- Large explosion proof Signal Beacons with excellent visibility for long distance
- A variety of light source selections from bulb, LED, and xenon lamp
- Aluminum housing provides excellent durability
- Fully enclosed structure with protection rating of IP66
- Integrated housing and terminal box model

※ Usable voltage AC120V: AC110V-120V, AC230V: AC220V-230V

### SEALR Explosion Proof LED Revolving Warning Light

Model number	Voltage	Current	Certificates	Weight	Color
SEALR	DC24V	120mA		5.33kg	● R-Red
	AC120V	90mA		5.74kg	● A-Amber
	AC230V	60mA		5.74kg	● G-Green ● B-Blue

- Excellent omni-directional visibility with LED light collecting system and special multifaceted reflector
- Revolving speed: 120-140RPM

### SEAL Explosion Proof LED Steady/Flashing Signal Light

Model number	Voltage	Current	Certificates	Weight	Color
SEAL	DC24V	110mA		4.87kg	● R-Red
	AC120V	90mA		5.25kg	● A-Amber
	AC230V	60mA		5.25kg	● G-Green ● B-Blue

- Long-lasting high intensity LED light source
- Suitable for applications where bulb replacement is difficult
- Built-in steady/flashing selection switch
- Flashing rate: 60-80 flashes/min

### Customization

- Explosion proof cable gland attached type available (Standard type does not come with explosion proof cable gland)
- 2 ways cable entries
- Customized cable entry (3/4" NPT, M20×1.5, M25×1.5) available

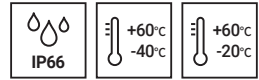

## SEAS Explosion Proof Xenon Lamp Strobe Signal Beacon

Model number	Voltage	Current	Xenon lamp			Certificates	Weight	Color	
			Spec	Standard	Parts no				
SEAS	DC24V	500mA		EUB0641	48		5.39kg	● R-Red	
	AC120V	150mA	200V -550V	-1A(G)				5.35kg	● A-Amber
	AC230V	110mA		U type				5.35kg	● G-Green ● B-Blue



SEAS



SEA

- Lamp connector fastening structure allows for convenient lamp replacement
- Excellent long-distance visibility with strong strobe signal diffusion
- Flashing rate: 60-80 flashes/min

## SEA Explosion Proof Bulb Revolving Signal Beacon

Model number	Voltage	Current	Bulb			Certificates	Weight	Color
			Spec	Standard	Parts no			
SEA	DC24V	850mA	24V15W	G23 15S	18		5.36kg	● R-Red
	AC120V	200mA	12V15W	G23 15S	17			● A-Amber
	AC230V	110mA	12V15W	G23 15S	17			● G-Green ● B-Blue

- Excellent diffusion effect with special multifaceted reflector
- Revolving speed: 120-140RPM

### Technical Diagram

Units: mm

· SEALR / SEAL / SEAS / SEA

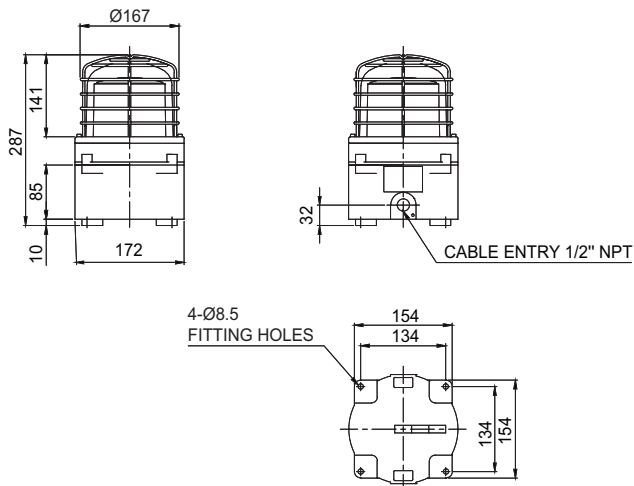

### Ordering Specification

<b>SEA</b>	-	<b>230</b>	-	<b>R</b>	-	<b>IECEX</b>
[Model number]		[Voltage]		[Color]		[Certificates]
SEALR		24-DC24V		● R-Red		IECEX
SEAL		120-AC120V		● A-Amber		ATEX
SEAS		230-AC230V		● G-Green		KCs
SEA				● B-Blue		CCC(NEPSI) TS