

1 2 3 4 5 6

MARK	DATE	REVISION	REVISER	APP. BY
①				
②				
③				

MODEL NO	SW2TS-AL
MATERIAL	HEAD & BODY - SUS316L BOLT, NUT & ETC.-SUS304
CONTACT	2CKT-DB, 1A1B, 250VAC 6A
PROTECTION GRADE	WATER & DUST PROOF-IP66
CABLE ENTRY	PF1/2"
COLOR	MAKER STANDARD
INSULATION RESISTANCE	100MΩ MIN. AT 500V DC

■ Operating Characteristics

OF max.g	1,380
RF min.g	260
PT	25° ± 5°
MD max.	10°
TT min	70°

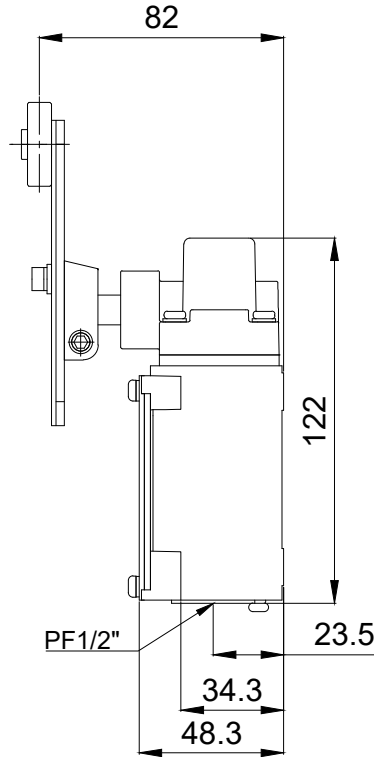
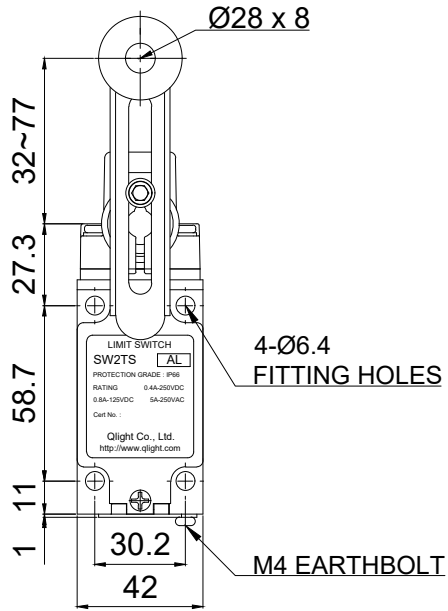

FOR LINEAR DIMENSIONS	ISO2768-1 : CLASS OF TOLERANCE				SURFACE FINISH
	f	m	Ⓢ	v	
0.5-3			±0.2	-	
3-6	±0.05	±0.1	±0.3	±0.5	
6-30	±0.1	±0.2	±0.5	±1	
30-120	±0.15	±0.3	±0.8	±1.5	
120-400	±0.2	±0.5	±1.2	±2.5	
400-1000	±0.3	±0.8	±2	±4	
FOR ANGULAR DIMENSIONS	0-10	±1°	±1°30'	±3°	
	10-50	±0°30'	±1°	±2°	
	50-120	±0°20'	±0°30'	±1°	
	120-400	±0°10'	±0°13'	±0°30'	

-		-		-		-		-	
Nr.	DWG. NO.	TITLE/NAME		MAT'L	QTY	REFERENCE			
DSND BY	CHKD BY	CHKD BY	APRV BY	VIEW	DATE				
J.I.BAE	Y.H.JOO		J.K.HAN	3	2025.06.29				
TITLE				MODEL					
SW2TS-AL				SW2TS-AL					
OUTLINE DRAWING				SW2TS-AL-OUT					
				DWG. NO.					
				SW2TS-AL-OUT					
SCALE	SIZE	REV	SHEET						
N/S	A4	00	1/1						

1 2 3 4 5 6 A4(297X210)