

Alarm Bells with Lamp for Vessels and Heavy Industrial Applications

SAB Series

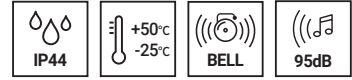

SAB130-Bell housing Ø130mm SAB200-Bell housing Ø200mm

PRODUCT SPECIFICATION

SAB130 | SAB200

Materials Bell-Steel, Housing-ABS
Ambient operating temperature -25°C to +50°C
Protection rating IP44
Standard color Housing-beige, Bell/Lamp-Red
Cable entry Ø20

- Electric solenoid bell system provides excellent durability to vibration and shock for vessels and large facilities
- Special material for bell housing provides clear and crisp alarm sound
- Easy wiring and maintenance with terminal box attached
- Lamp attached provides visual signals
- Bell and lamp operation is synchronized.



SAB130
(Max.95dB)

SAB130 / SAB200 Alarm Bells with Lamp for Vessels and Heavy Industrial Applications , Max.95dB

Model number	Frequency	Volume	Bell diameter	Voltage	Current	Certificates	Weight	Color
				DC24V	1.3A			
SAB130	400	Max.95dB	130mm	AC110V	380mA	CE	1.88kg	● R-Red
SAB200	-600Hz		200mm	AC220V	300mA			



SAB200
(Max.95dB)

Technical Diagram

Units: mm

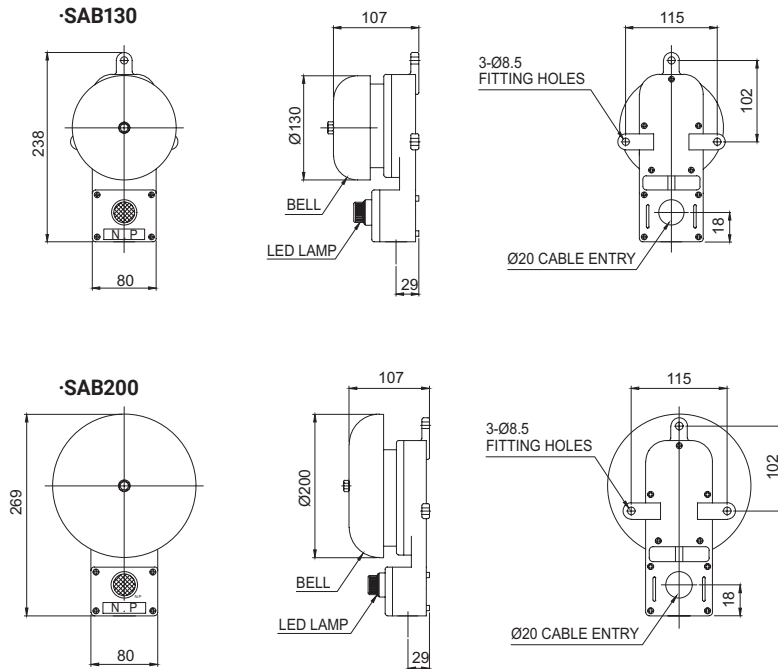

Precautions for Use

- The continuous operation of the product is up to 3 minutes.

Customization

- Two way cable entries with PG19

Ordering Specification

SAB200	-	110	-	CG
[Model number]		[Voltage]		[Cable gland]
SAB130 SAB200		24-DC24V 110-AC110V 220-AC220V		None-Back wiring type CG-Built-in cable gland type