

QST50M-Ex



QST50M-Ex

PRODUCT SPECIFICATION

QST50M-Ex | QST50BM-Ex

Materials

Lens-PC, Light diffusion Lens-PC, Housing-Al, Cover-Al

Ambient operating temperature $-40^{\circ}\text{C} \leq \text{Tamb} \leq +60^{\circ}\text{C}$

Explosion protection rating

IECEX - Ex db IIC T6 Gb

Ex tb IIIC T85°C Db

ATEX - II2G Ex db IIC T6 Gb

II2D Ex tb IIC T85°C Db

Certificates IECEX, ATEX, KCs, CCC

Housing standard color Silver

Cable entry M12 or M16xP1.5

Flashing rate 60-80 flashes/min

- Ex db IIC T6 Gb rated flame/dust ignition proof LED tower light for use in explosive gas areas
- Excellent long-distance visibility by applying a special light diffusion tube that condenses LED light
- Features superior durability with aluminum housing
- Semi-permanent service life with long-lasting LED light source

QST50M-Ex Flame/Dust Ignition Proof Slim LED Signal Tower Light with Terminal Block

Model number	Layer	Voltage	Certificates	Weight	Color
QST50M-Ex	5	DC24V AC110V-230V		1.21Kg	<ul style="list-style-type: none"> ● R-Red ● A-Amber ● G-Green ● B-Blue ○ W-White

Light source current(based on 1 layer)

Voltage	DC24V	AC110V-230V
Light source current(1 layer)	75mA	Max.55mA

Ordering Specification

QST50M-Ex	-	5	-	24	-	RAGBW	-	IECEX
[Model number]		[Layer]		[Voltage]		[Color]		[Certificates]
QST50M-Ex		5-5Layers		24-DC24V 110/230-AC110V-230V		<ul style="list-style-type: none"> ● R-Red ● A-Amber ● G-Green ● B-Blue ○ W-White 		IECEX ATEX KCs CCC

Flame/Dust Ignition Proof Slim LED Signal Tower Light with Built-in Buzzer

QST50BM-Ex

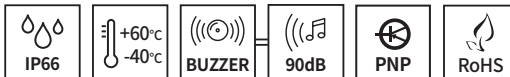

QST50BM-Ex Flame/Dust Ignition Proof Slim LED Tower Light with Built-in Buzzer & Terminal Block

Model number	Layer	Voltage	Certificates	Weight	Color
QST50BM-Ex	5	DC24V AC110V-230V		1.39Kg	<ul style="list-style-type: none"> ● R-Red ● A-Amber ● G-Green ● B-Blue ○ W-White



QST50BM-Ex

Light source/buzzer current(based on 1 layer)

Voltage	DC24V	AC110V-230V
Light source current(1 layer)	75mA	Max.55mA
Buzzer current	50mA	Max.40mA

Explosion proof structure for buzzer model

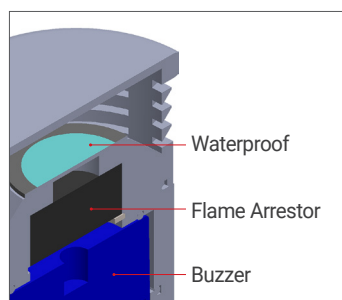

· FLAME ARRESTER
A flame arrester(also called a deflagration arrester) functions by absorbing the heat from a flame front traveling at sub-sonic velocities, thus dropping the burning gas/air mixture below its auto-ignition temperature: consequently, the flame cannot survive. The heat is absorbed through channels (passages) designed into an element.

Ordering Specification

QST50BM-Ex	-	5	-	24	-	RAGBW	-	IECEX
[Model number]		[Layer]		[Voltage]		[Color]		[Certificates]
QST50BM-Ex		5-5Layers		24-DC24V 110/230-AC110V-230V		<ul style="list-style-type: none"> ● R-Red ● A-Amber ● G-Green ● B-Blue ○ W-White 		IECEX ATEX KCs CCC

Flame/Dust Ignition Proof Slim LED Signal Tower Light

QST50-Ex Series

Technical Diagram

Units: mm

·QST50-Ex-5: DC/AC

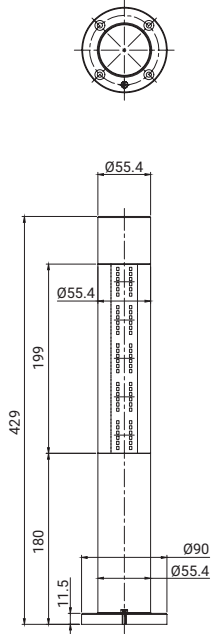

HOLE FOR CABLE ENTRY
Quantity : 1
Size : M12xP1.5 or M16xP1.5

·QST50B-Ex-5: DC/AC

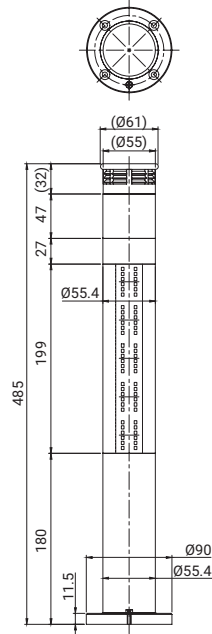

HOLE FOR CABLE ENTRY
Quantity : 1
Size : M12xP1.5 or M16xP1.5

·QST50M-Ex : AC/DC

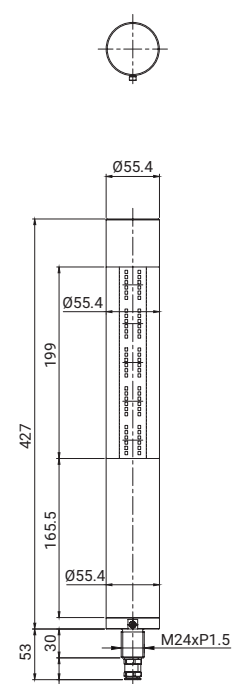

HOLE FOR CABLE ENTRY
Quantity : 1
Size : M12xP1.5 or M16xP1.5

·QST50T-Ex-5: DC/AC

HOLE FOR CABLE ENTRY
Quantity : 2
Size : M16, M20xP1.5 or NPT 1/2, 3/4

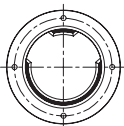
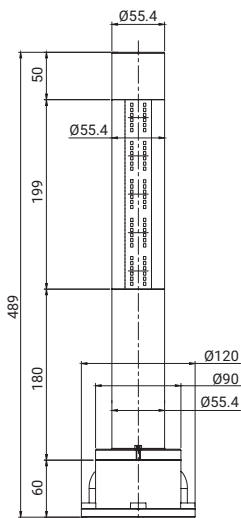
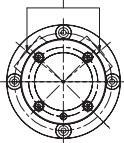

·QST50BT-Ex-5: DC/AC

HOLE FOR CABLE ENTRY
Quantity : 2
Size : M16, M20xP1.5 or NPT 1/2, 3/4

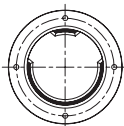
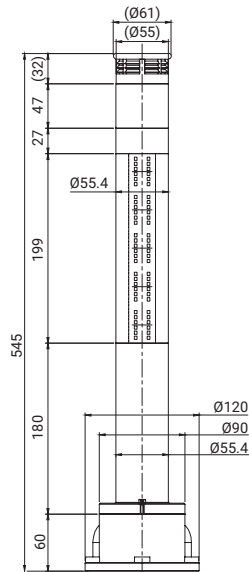
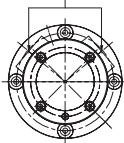

·QST50BM-Ex : AC/DC

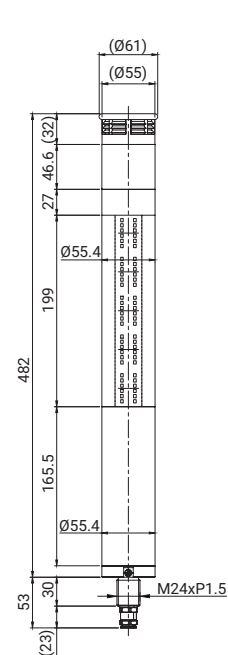
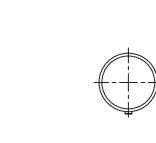

HOLE FOR CABLE ENTRY
Quantity : 1
Size : M12xP1.5 or M16xP1.5

Wiring Instructions

- QST50-Ex Series can be wired with either External Contact or transistor.
- In case of wiring by transistor, please make sure if it is NPN type or PNP type. Please follow wiring instructions below.

External Contact

DC
Steady/Flashing

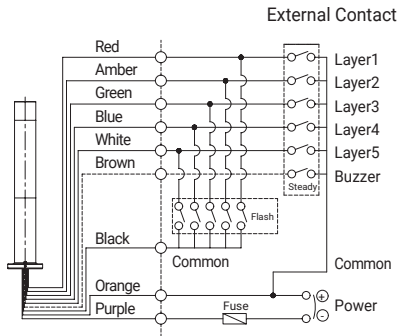

Transistor

External transistor-PNP

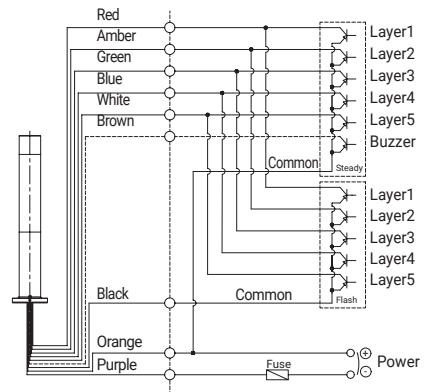

AC
Steady/Flashing

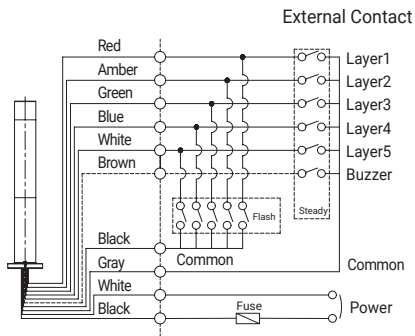

External transistor-PNP

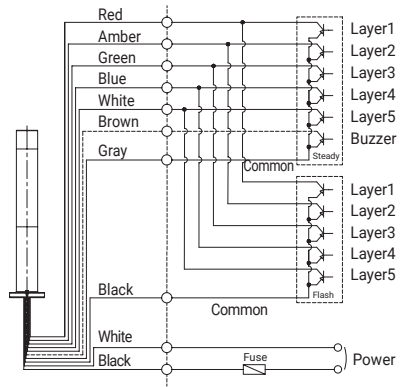

QST50-Ex Series



Terminal Wiring Information

