

Ø80mm LED Strobe Signal Light for Forklift

S80 Series



Enhanced visibility by adopting a diffusion lens

PRODUCT SPECIFICATION

S80LS

Materials Lens-AS, Housing-ABS
Ambient operating temperature -30°C to +50°C
Protection rating IP65
Flashing rate 60-80/min

- Ø80mm LED strobe signal light
- Extremely bright signal light that reduces attenuation of the signal light
- Excellent visibility in daytime as bulb or xenon lamp
- Vibration and water resistance product



S80LS

S80LS LED Strobe Signal Light for Forklift

Model number	Voltage	Current	Certificates	Weight	Color
S80LS	DC12V-24V	Max.190mA	 	0.25kg	<ul style="list-style-type: none"> ● R-Red ● A-Amber ● G-Green ● B-Blue

- ※ DC type model has a free-voltage range of 10V-30V
- ※ UL compliant: DC24V

Technical Diagram

Units: mm

·S80LS

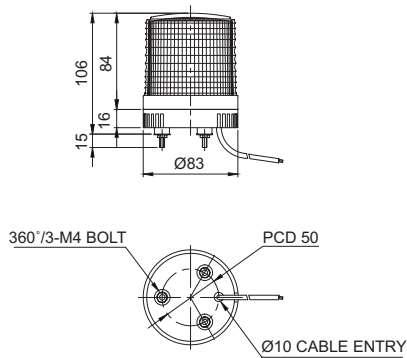

Wiring Instructions

- External Power line - UL2095 AWG20(0.5sq) x 2C 400mm
- This product can be wired regardless of polarity.

Ordering Specification

S80LS	-	12/24	-	R
[Model number] S80LS		[Voltage] 12/24-DC12V-24V		[Color] <ul style="list-style-type: none"> ● R-Red ● A-Amber ● G-Green ● B-Blue