

ETG50L

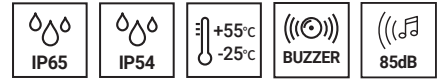

PRODUCT SPECIFICATION

ETG50L

Materials Housing-ABS, Lens-PC
Ambient operating temperature -25°C to +55°C
Volume Max. 85dB at 1m
Protection rating IP65/IP54

- Ø50mm LED signal tower light of performance line
- Vivid transmission of color using tinted lenses
- Excellent long-distance visibility by using high-brightness LED light source
- Waterproof and dustproof model that meets IP65 protection rating
- Equipped with a foldable bracket to respond to various external environments
- Built-in buzzer type available



ETG50L

ETG50L Industrial LED Beacon

Model number	Layers	Voltage	Current	Certificates	Weight	Color
ETG50L Steady	3	DC24V	55mA	CE	0.42kg	● R-Red ● A-Amber ● G-Green
ETG50L-BZ Steady w/built-in buzzer						

Wiring Instructions

- ETG50L series can be wired by using both external contact and transistor.
- Wiring to transistor, use the PNP transistor. Please wire properly based on wiring instructions.

ETG50L / ETG50L-BZ

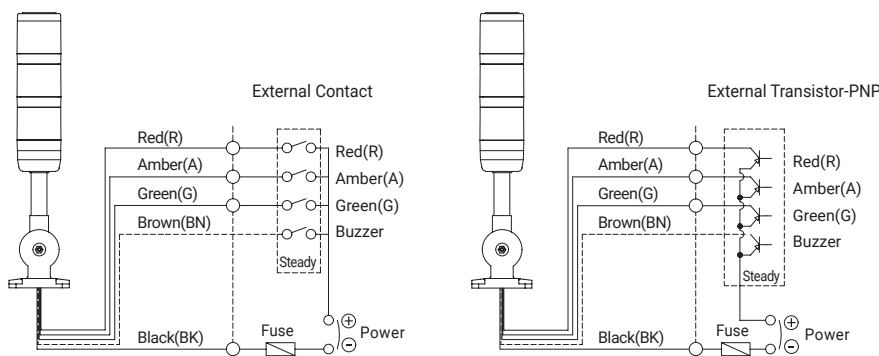

※ ETG50L / ETG50L-BZ: Steady

Technical Diagram

Units: mm

ETG50L / ETG50L-BZ

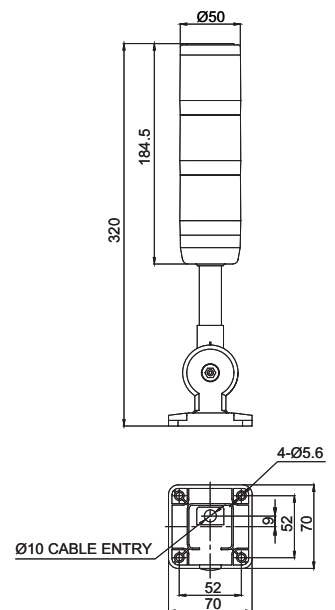

Ordering Specification

ETG50L	-	24	-	RAG
[Model number] ETG50L ETG50L-BZ		[Voltage] 24-DC24V		[Color] ● R-Red ● A-Amber ● G-Green