

ETR50L

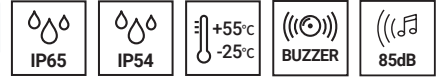

ETR50L

PRODUCT SPECIFICATION

ETR50L

Materials Housing-ABS, Lens-PC
Ambient operating temperature -25°C to +55°C
Volume Max. 85dB at 1m
Protection rating IP65/IP54

- Ø50mm LED signal tower light of performance line
- A soft and cozy signal light is emitted through the translucent lens
- Excellent long-distance visibility by using high-brightness LED light source
- Waterproof and dustproof model that meets the IP65 protection rating
- Equipped with a foldable bracket to respond to various external environments
- Built-in buzzer type available

ETR50L Industrial LED Beacon

Model number	Layers	Voltage	Current	Certificates	Weight	Color
ETR50L Steady						● R-Red
ETR50L-BZ Steady w/built-in buzzer	3	DC24V	55mA	CE	0.42kg	● A-Amber ● G-Green

Technical Diagram

Units: mm

·ETR50L / ETR50L-BZ

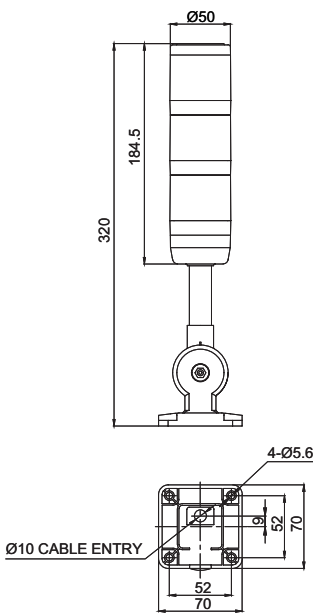

Wiring Instructions

- ETR50L series can be wired by using both external contact and transistor.
- Wiring to transistor, use the PNP transistor. Please wire properly based on wiring instructions.

·ETR50L / ETR50L-BZ

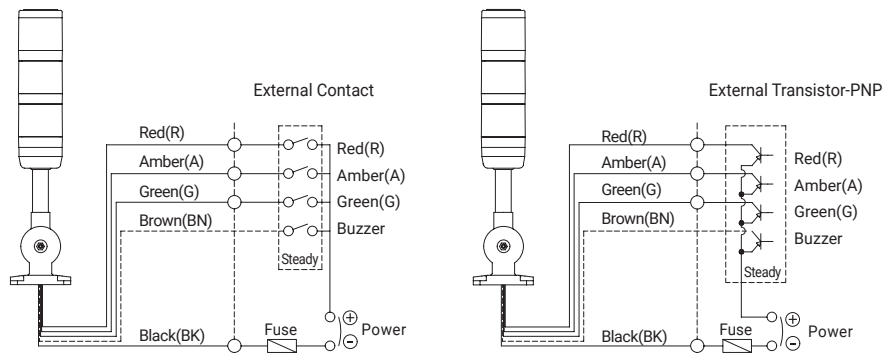

※ ETR50L / ETR50L-BZ: Steady, ETR50LF / ETR50LF-BZ: Flashing

Ordering Specification

ETR50L	-	24	-	RAG
[Model number]		[Voltage]		[Color]
ETR50L ETR50L-BZ		24-DC24V		● R-Red ● A-Amber ● G-Green