

# LED Work Lights

## EPL Series

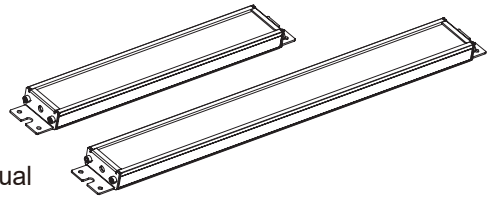

Thank you for purchasing Qlight's products. Please read this user manual carefully prior to installation and operation to ensure safe and correct use.

### ⚠ Precautions for Safety

Failure to follow the instructions below may cause a loss of life or serious physical injury.

1. During wiring or maintenance, please completely turn off the power of the product. (Failure to follow this may lead to an electric shock.)
2. Do not install the product in locations that subjects it to excessive dust or water other than the conditions designated by the IP protection ratings indicated for each product. (Failure to follow these instructions may cause a fire to the product, electric shock, physical injury, malfunction or damage to the product.)
3. Do not alter or repair this product. If maintenance or repair service is required, please contact your local Qlight contact point. (Failure to follow these instructions may lead to fire, electric shock, or product damage.)
4. Please apply the correct voltage to the product. (Failure to follow these instructions may lead to fire, electric shock, or product damage.)
5. When the product is applied to a condition that may impact lives or property, please make sure to have a double safety device. (Failure to follow this may cause damage to property, fire, electric shock and loss of life.)

### ⚠ Precautions for Correct Use

Failure to follow the proper instructions may cause damage to property, the product, or malfunction of the product that would void the warranty.

1. Please remove any objects that can interrupt ventilation around the product.
2. Please turn off the power of the product immediately if it fails to operate properly.
3. Carefully wire the product according to each product's specification.
4. Please be careful in preventing chemicals such as thinner, benzene, etc. in contact with the surface of the product.
5. Do not apply excessive force/impact to the product.
6. Failure to follow any of the instructions above may cause malfunction or damage to the product, fire, and electric shock.

### Ordering Specifications

EPL	-	380	-	24
[Model number]		[Product length]		[Voltage]
EPL		380-391mm 550-556mm		24-DC24V

### Dimensions

(Units : mm)

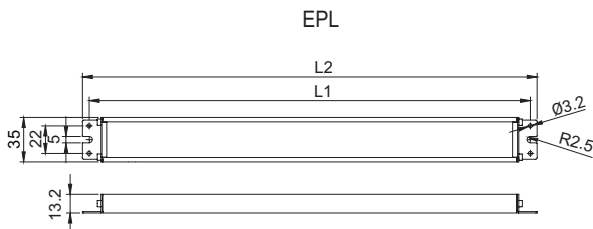

Model number	L1	L2
EPL380	380	391
EPL550	545	556

### Product Specifications

#### ■ Optics Specifications

Model number	EPL380	EPL550
Lens Color	Translucent	
Directions	Cooldaylight	
Light color	6,000-6,500K	
Luminous flux	DC 1,000lm	1,600lm
Efficacy(lm/W)	DC 330Lux	570Lux

#### ■ Specifications

Model number	EPL380	EPL550
Voltage	DC24V	
Range for operation voltage	DC24V	
Power consumption	DC24V 15W	24W
Insulation resistance	Min. 100MΩ(500V DC mega ohm meter)	
Withstanding voltage	DC:500VAC, 60Hz, 1minute/AC:1,500VAC, 60Hz, 1minute	
Operating temperature	-25°C to +55°C	
Protection rating	IP50	
Materials	Housing-AL, Lens-PC	
Certification	CE	
Weight(Approx.)	0.27kg	0.40kg



Please scan the QR code for more detailed product information.

[www.qlight.com](http://www.qlight.com)

## Wiring Instructions

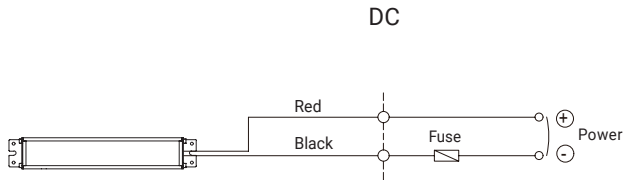

## Installation Environment and Protection Rating

- This product is designed for indoor use with protection rating of IP50.
- If the product is installed in locations that subject it to excessive dust or water other than the designated IP protection rating indicated, it may cause malfunction or damage to the product.
- For further information, please visit our website ([www.qlight.com](http://www.qlight.com)).

## Mounting Hole Specifications

- Machine holes on the mounting surface referring to the diagram below.

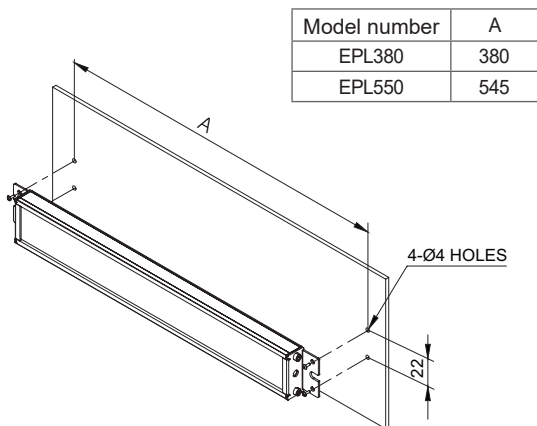

## Parts Definition/ Installation

### Parts Definition

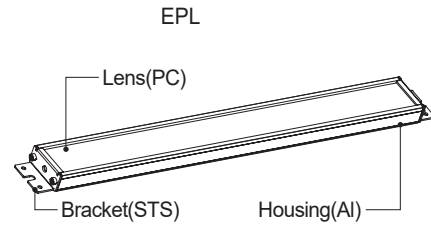

### Installation

- First, machine taps or holes on the mounting surface ①.
- The mounting hole of this product is 3.2mm in diameter.
- When machining taps, fasten the bolt through the mounting hole of the product.
- When machining holes, insert the bolt through the hole of the product, and tighten the nut from the opposite side of the mounting surface.

